

the GENERAL RADIO Experimenter

Copyright 1954 • GENERAL RADIO COMPANY, Cambridge, Mass., U. S. A.

Since 1915 — Manufacturers of Electronic Apparatus for Science and Industry

VOLUME XXIX No. 5

OCTOBER, 1954

UNMOUNTED MOTOR SPEED CONTROLS FOR ASSEMBLY INTO OTHER EQUIPMENT

● **TO MEET** a definite customer demand, we have for some time supplied, on special order, "stripped-down" models of our Variac® Motor Speed Controls. These have had such a wide acceptance by manufacturers of motor-powered equipment that they are now made available as standard catalog items and will be carried in stock.

These models include the basic components of the original controls but omit the switches, overload protection, and cabinet. The elements are mounted on a base plate, and all connections are brought out to a terminal strip. The Variac® Autotransformer, which is the

speed control element, is included as a separate unit and can be mounted with the starting switch in any convenient location.

Although intended primarily for machine manufacturers, the stripped-down controls are also used frequently to avoid duplicating the auxiliary components in applications where special switching circuits are required. These controls should be considered for possible cost savings whenever special wiring is involved or when a suitable protected location for the basic unit is available, such as in the cabinet of the driven machine.

Figure 1. View of the Type 1700-BW Variac Speed Control. Transformers, rectifiers, and choke are assembled to a metal chassis, which can be mounted in the cabinet of the driven machine. Location of the Variac® Autotransformer and the necessary switching can then be dictated by operating convenience.

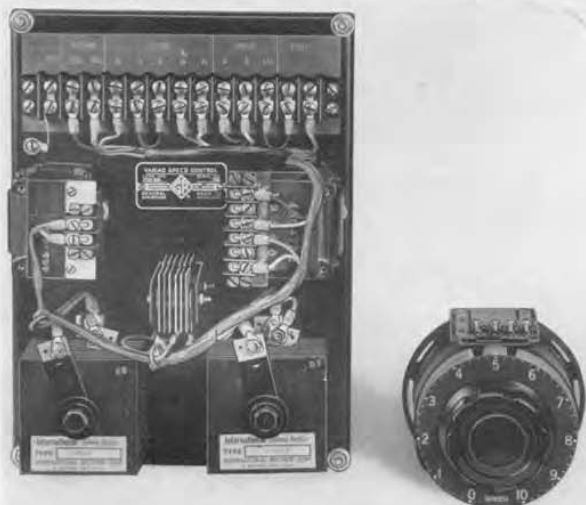

IET LABS, INC in the GenRad tradition

534 Main Street, Westbury, NY 11590

TEL: (516) 334-5959 • (800) 899-8438 • FAX: (516) 334-5988

www.ietlabs.com

Also

IN THIS ISSUE

Page

CABLE TESTING CONSOLES USE GENERAL RADIO EQUIPMENT.....	5
MIDORIYA TO BE GENERAL RADIO REPRESENTATIVE IN JAPAN.....	8

Figure 1 shows pictorially, and Figure 2 in schematic form, the components and connections in these basic control assemblies. The model shown is TYPE 1700-BW, with a rating of $\frac{1}{3}$ horsepower. All parts are mounted on a metal chassis, with leads brought out to a convenient terminal strip for connection to the external control elements.

Figure 3 shows how connections are made to the terminal strip to perform the functions of starting, stopping, braking, reversing, and overload protection.

The start-stop-reverse control may be either a toggle switch or drum-type controller. A magnetic circuit breaker of the relay type can be used instead of the fuses and line switch shown. When only a single direction of rotation is required without dynamic braking, the only auxiliary components needed are the line switch and fuses. Other circuit arrangements with a list of suitable components are given in the Operating Instructions.

Variac Motor Speed Controls are versatile, general-purpose devices for operating d-c shunt or compound motors from a-c power lines. They have constant-torque characteristics, that is, the same maximum torque can be provided at all speed settings. They are suitable for all applications except where speed must be precisely maintained under varying load or where speed must be

Figure 2. Schematic circuit diagram of the stripped-down speed control. All terminals are clearly identified, as shown.

PANEL COMPONENTS

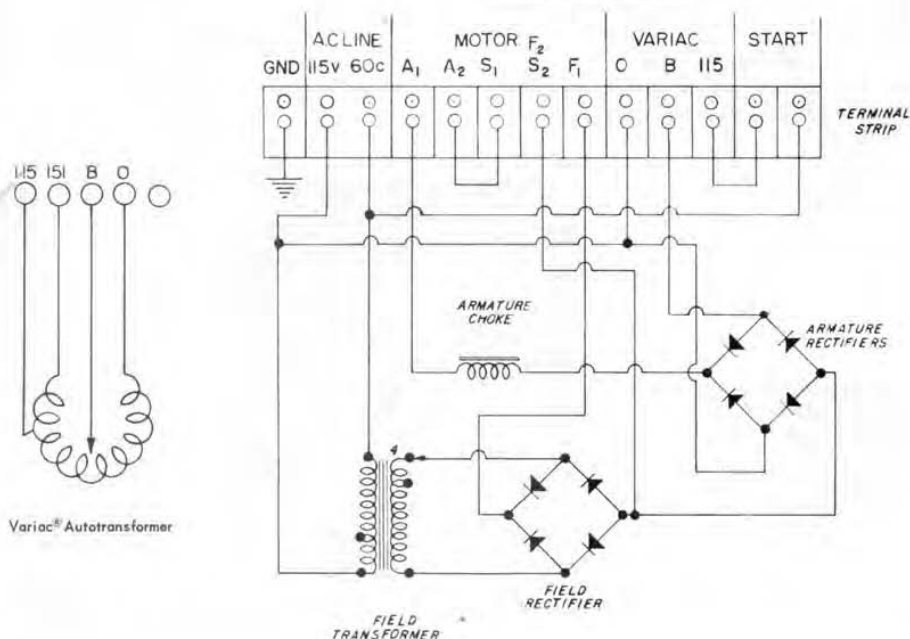



SPECIFICATIONS

TYPE NUMBER	1701 AKW	1701 AUX	1703 AW	1700 BW	1702 AW	1704 AW	1705 AW
Motor Horsepower Range	$\frac{1}{2}$ & less	$\frac{1}{2}$ & less	$\frac{1}{2}$ to $\frac{1}{2}$	$\frac{1}{4}$ and $\frac{3}{4}$	$\frac{3}{2}$ and $\frac{3}{4}$	1	$1\frac{1}{2}$
Power Supply (Single Phase 60 cycles)	115 1.5	115 1.5	115 2.2	115 5	115 10	230 6.5	230 8.5
Line Voltage Limits	105-125	105-125	105-125	105-125	105-125	210-250	210-250
Input Power—Watts	175	175	255	560	1150	1500	1950
Motor Control Output — DC	None	None	30	50 approx.	65	90	90
Armature	0.8 0-115	0.8 0-115	1.5 0-115	3 0-115	6.5 0-115	4.5 0-230	6 0-230
Field	0.2	1.25	1.0	0.4	0.4	0.5	0.5
Speed Range	115 0 to 2 rated	38 10 16 0 to 2 rated	115 0 to 115 rated	48 0 to 1.3 rated	75 0 to 1.15 rated	115 0 to 1.15 rated	128 0 to 1.25 rated
Dynamic Braking	Not included — can be provided by user						
Armature Overload Protection	Not included — to be provided by user						
Control Station	Speed control element (Variate) furnished — Start, stop, reverse, and braking controls to be provided by user						
Over-all Dimensions (Inches)	Chassis Variate	$6\frac{1}{4} \times 9\frac{1}{2} \times 2\frac{1}{4}$ $3\frac{1}{4} \times 3\frac{1}{2} \times 4\frac{1}{2}$	$6\frac{1}{4} \times 10 \times 3$ $3\frac{1}{4} \times 3\frac{1}{2} \times 4\frac{1}{2}$	$9 \times 12\frac{1}{2} \times 3\frac{1}{4}$ $4\frac{1}{2} \times 5 \times 5\frac{1}{2}$	$10\frac{1}{2} \times 15 \times 4\frac{1}{2}$ $6\frac{1}{2} \times 6\frac{1}{2} \times 5\frac{1}{2}$	$19\frac{1}{2} \times 11\frac{1}{2} \times 3\frac{1}{2}$ $7\frac{1}{2} \times 9\frac{1}{2} \times 5\frac{1}{2}$	$19\frac{1}{2} \times 13\frac{1}{2} \times 3\frac{1}{2}$ $7\frac{1}{2} \times 9\frac{1}{2} \times 5\frac{1}{2}$
Net Weight (pounds)	Chassis Variate	$2\frac{1}{2}$ $3\frac{1}{2}$	3 $3\frac{1}{2}$	$11\frac{1}{2}$ 7	$17\frac{1}{2}$ $11\frac{1}{2}$	24 21 $\frac{1}{2}$	30* 21 $\frac{1}{2}$
Recommended Motor†	Mod-5	Mod-4	M68-11	Mod-3	Mod-6	Mod-9	Mod-10
Code Word	SABOT						
Price††	SALTY SATIN SAVOR SAXON						
1 to 4 units	\$67.00	\$67.00	\$93.00 ea.	\$135.00 ea.	\$195.00 ea.	\$310.00 ea.	\$325.00 ea.
5 to 19 units	63.50	63.50	83.70 ea.	122.00 ea.	177.50 ea.	295.00 ea.	315.00 ea.
20 and up units	60.50	60.50	79.00 ea.	116.00 ea.	170.00 ea.	280.00 ea.	300.00 ea.

* Approximate

† For motor specifications and prices, see *Experimenter* for December, 1953.

†† All prices are net, L.O.B. factory.



adjusted in response to an electrical control voltage rather than by manually turning a control knob. Speed is maintained sufficiently closely for most process work, even under heavy load, provided that the load is reasonably constant.

The many advantages of Variac Speed Controls — wide range, smooth adjustment, high starting torque, quick reversing, no torque pulsation, simple installation, and low maintenance — have made them unusually satisfactory in a variety of applications. On lathes and other machine tools, they are used for both spindle and feed drives; on precision grinders, their freedom from torque pulsation gives exceptional finish; they

have performed well on winders, rewind and take-up drives of many kinds; their smoothness of adjustment is desirable in machining plastics and in lapping lenses; they have been very successfully used in conveyor drives.

The availability of stripped-down models in all standard ratings will make it possible to provide the superior performance of Variac Speed Controls in a wider field of applications.

SEND FOR BOOKLET

A new booklet, entitled "Performance Characteristics and Engineering Data for Variac Motor Speed Controls," is now available. We shall be glad to mail you a copy upon request.

Figure 3. Wiring diagram for simple switching to perform the basic functions of starting, stopping, reversing, and braking for a shunt motor. Armature overload protection is provided by fuses in the armature leads. Since the motor has no series field, the S₁S₂ terminals are shorted.

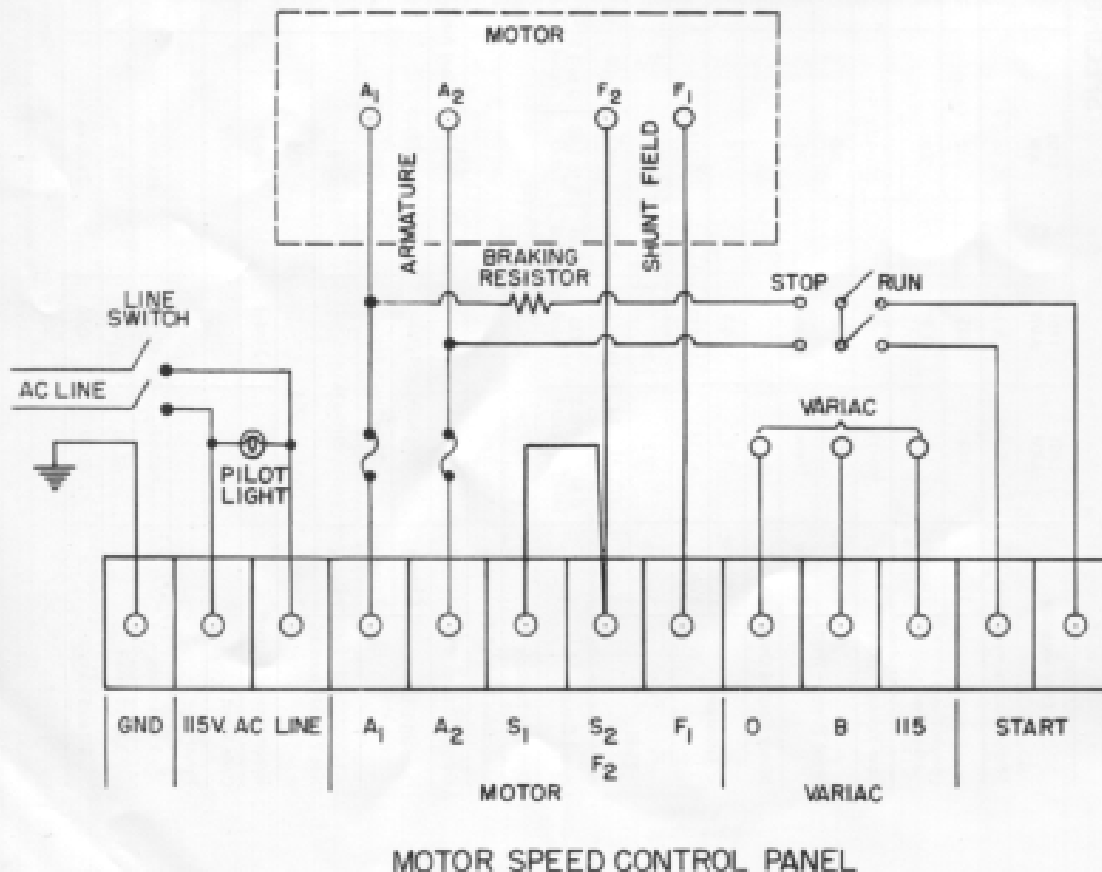



CABLE TESTING CONSOLES USE GENERAL RADIO EQUIPMENT

The test consoles described in this article are interesting examples of how the products of several manufacturers can be grouped together for making a specified series of tests. For the information on which this article is based, we are indebted to Mr. E. Mark Wolf, Electrical Engineer of Rome Cable Corporation.

One of the products of the Rome Cable Corporation of Rome, N. Y., is Spiral Four Cable, a four-conductor shielded cable, $\frac{3}{8}$ inch in diameter, with polyethylene insulation and with polyvinyl chloride outer sheath. This cable is used by the Signal Corps, U. S. Army, for carrier voice communication and for teletype and facsimile communication. It is furnished to the Signal Corps in standard lengths with watertight connectors attached.

Because this cable is used at carrier frequencies, its capacitance and resistance must be held within narrow limits, and, hence, production tests must be made with laboratory precision. Tests are divided into four parts:

1. Preliminary electrical test.
2. Final electrical test.
3. AC/DC resistance measurement.
4. Connector water seal test.

Special test consoles for making the preliminary and final tests were designed by the Rome Cable Corporation and built for them by the Power Equipment Company of Detroit, Michigan.

Preliminary Electrical Tests

Figure 1 shows the console for preliminary electrical tests. The instruments shown are:

- General Radio TYPE 716-C Capacitance Bridge
- General Radio TYPE 1231-B Amplifier and Null Detector



Figure 1. View of the console for preliminary electrical tests. The Type 716-C Capacitance Bridge is at the right, the Type 1231-B Amplifier and Null Detector at the top center of the pouch. At the left part face of the console is the Variac[®] Autotransformer.



General Radio TYPE 723-C 1000-cycle Vacuum-Tube Fork

General Radio TYPE V20M Variac[®] Autotransformer

Leeds and Northrup Wheatstone bridge and galvanometer

Siemens & Halske Coupling Meter

Peerless 115V to 1500V transformer, meters, timers, switches, indicators, etc.

Seven of these consoles are used at Rome Cable. Tests performed are as follows:

1. *High Voltage*—This test is performed to detect defective cable before the connectors are attached. 1500 volts is applied between all four conductors and shield for 15 seconds. Voltage is adjusted by means of the Variac.

2. *Mutual Capacitance* — Measured on each pair of the cables, using the TYPE 716-C Capacitance Bridge. The oscillator supplying power to the bridge is the TYPE 723-C Vacuum-Tube Fork, and the detector is the TYPE 1231-B Amplifier and Null Detector.

3. *Capacitance Unbalance* — Side-to-side and side-to-ground capacitance unbalance is measured with the Siemens &

Halske Coupling Meter and the General Radio oscillator and null detector, as used in (2) above.

4. *D-C Copper Resistance* — Measured for each pair with the Leeds and Northrup bridge and galvanometer.

Final Electrical Tests

The console for these tests is shown in Figure 2. The instruments used are:

General Radio Variac Autotransformer and Peerless transformer, as in the preliminary test console.

General Radio TYPE 1861-A Megohmmeter

Leeds and Northrup Wheatstone bridge and galvanometer

Switching, meters, indicators, etc.

Five individual consoles are used.

Tests performed are as follows:

1. *High Voltage*—1500 volts ac for one minute, applied between each conductor in turn and the remaining three conductors and shield, all grounded. Test voltage is supplied by the Peerless transformer and adjusted by means of the Variac.

2. *Insulation Resistance* between each conductor in turn and the three remain-

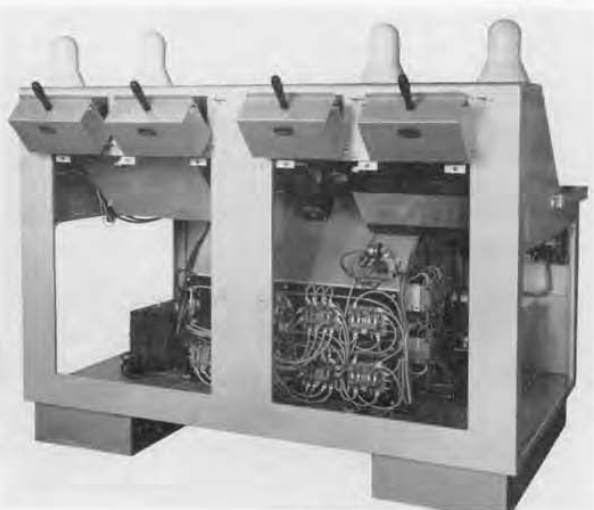

Figure 2. View of the console for final electrical tests. The General Radio Megohmmeter is at the right of the panel, and the Variac at the front face of the left-hand pedestal.





Figure 3. Rear view of the preliminary-electrical-test console, showing switching, relays, wiring, and details of construction.



ing conductors and shield, all grounded; measured with the General Radio TYPE 1861-A Megohmmeters.

3. *D-C Copper Resistance* of each pair is measured with the Leeds and Northrup bridge and galvanometer.

4. *Braid Continuity*, and

5. *Conductor Continuity* — These tests are made by completing an electrical circuit with the cable assembly in series with an indicating lamp and power source.

These test consoles have been in use for nearly three years and have been completely satisfactory. Other cable companies, with the permission of Rome Cable, have had similar units built for their use in testing the same type of cable.

In addition to the tests made at the consoles, two other measurements involve

the use of General Radio instruments, the AC/DC Resistance Measurement and the Connector Water Seal Test.

The ratio of a-c resistance at 60 kc to the d-c resistance of the cable is measured with a 60-kc Network Manufacturing Co. Impedance Bridge, in which a number of General Radio components are used. The power source is a General Radio TYPE 1302-A Oscillator, and the detector a General Radio TYPE 1231-B Amplifier and Null Detector with a TYPE 1231-P5 Filter.

The Connector Water Seal Test checks the ability of mated or capped connectors to be immersed in water without a decrease in insulation resistance greater than that specified. Measurements are made before and after immersion, using a portable General Radio TYPE 1862-A Megohmmeter.

MISCELLANY

VISITORS: We have welcomed recently at our Cambridge plant the following

visitors from foreign countries: G. R. Lawrance, Equipment Engineer, Stand-





ard Telephones & Cables, Ltd., Newport, England; Jean Brune, Chief Research Engineer, Lignes Telegraphiques et Telephoniques of Conflans, Ste. Honorine, France; Peter J. A. Goebels, Vocational Specialist, National Economic Ministry, Germany; Dr. Erwin K. H. Krause, Director, Institute for Vocational Education, Bonn, Germany; Prof. Erik Hallen, L'Ecole Royale Superieure Polytechnique, Stockholm, Sweden; Dr. Tino Gaumann, Organic Chemical Institute, Swiss Technical High School, Zurich, Switzerland; Nagatoshi Azuma, Chief, Design Section, Hitachi, Ltd., Yokohama, Japan; Yoshinohu Imamura, Engineer, Hitachi, Ltd., Yokohama, Japan; I. Kimura, Iida & Co., Tokyo, Japan; Dr. Yoji Ito, Kodan Electronics Co., Ltd., Tokyo, Japan; Isokazu Tanaka, Director, Kodan Electronics Co., Ltd., Tokyo, Japan; Ki Kato, Daisuke Kawata, Toku Uchida, Shigeki Yamato, Heijiro Yomezawa, Nippon Electric Co., Tokyo, Japan; S. Katsurai, Nippon Kikai Boeki Kaisha, Chuo-ku, Tokyo, Japan; Naokiti Tamaru, Manager, Shibaura Plant, Oki Electric Industry Co., Minato-Ku, Tokyo, Japan; Shuichiro Oka, Deputy Manager, Radio Engineering Dept., Tokyo Shibaura Electric Co., Ltd., Kawasaki, Japan.

MIDORIYA TO DISTRIBUTE GENERAL RADIO PRODUCTS IN JAPAN

We take pleasure in announcing the appointment of Midoriya Electric Company Ltd. as exclusive distributors of General Radio products in Japan.

Our friends and customers in Japan should address their orders and requests for information to

MIDORIYA ELECTRIC COMPANY LTD.
3, 4-Chome, Ginzanishi
Chuo-Ku, Tokyo

GENERAL RADIO COMPANY

275 MASSACHUSETTS AVENUE
CAMBRIDGE 39 MASSACHUSETTS
TELEPHONE: TRowbridge 6-4400

BRANCH ENGINEERING OFFICES

NEW YORK 6, NEW YORK
80 WEST STREET
TEL.—WOrth 4-2722

LOS ANGELES 38, CALIFORNIA
1000 NORTH SEWARD STREET
TEL.—Hollywood 9-6201

CHICAGO 5, ILLINOIS
920 SOUTH MICHIGAN AVENUE
TEL.—WAbash 2-3820

SILVER SPRING, MARYLAND
8055 13th STREET
TEL.—JUniper 5-1088

REPAIR SERVICES

WEST COAST
WESTERN INSTRUMENT CO.
826 NORTH VICTORY BOULEVARD
BURBANK, CALIFORNIA
TEL.—Victoria 9-3013

CANADA
BAYLY ENGINEERING, LTD.
FIRST STREET
AJAX, ONTARIO
TEL.—Toronto EMpire 8-6866

PRINTED
IN
U.S.A.

